



# MX1200TXP

## XPREP® Hi-Power Variable-Speed Food Blender with 48 oz. BPA-Free Copolyester Container



\*Made in USA with US and foreign parts.

### ELECTRICAL

Voltage: 120V

Frequency: 60Hz

Watts: 1560W

Amps: 12.5A

Plug Type: NEMA 5-15P

Cord Length: 6 feet



### MAIN FEATURES

- Heavy-duty, 3.5 peak HP, high-performance motor with 2-speed selection is the strongest in its class. It powers through the toughest ice and frozen fruit mixtures in seconds.
- \* Super-high 30,000+ RPM motor speed for the smoothest consistencies.
- Simple ON/Standby and Variable/PULSE paddle switches with variable-speed knob are easy to use and easy to find in a dimly lit location.
- Variable-speed control from 1,500 RPM to 20,000 RPM for maximum control over your blending—perfect for all types of food preparation.
- The Raptor® 48 oz. stackable BPA-free copolyester container.
  - Ultra-aggressive blade and jar design delivers smoother consistencies and faster results
  - Unbreakable, dishwasher-safe construction
- High-performance, high-impact stainless steel blade is user replaceable for easy servicing.
- Easily removable container cover with removable clear cap for adding ingredients and pressure reduction during hot food blending.
- User-replaceable, metal-on-metal stainless steel coupling system between base and container for durability and reliability.
- One-piece, dishwasher-safe, removable jar pad.
- Optional sound enclosure easily retrofits to base for noise reduction.
- Recommended for 75+ cycles per day.
- Limited Three-Year Motor and Two-Year Parts & Labor Warranty.

### SALES FEATURES

Get smooth, consistent results every time with the Waring® MX1200TXP. This heavy-duty, 3.5 HP blender offers maximum power and efficiency with the strongest motor in its class. Rev it up with variable speed controls from 1,500 to 20,000 RPM and a max pulse of 30,000 RPM. Perfect for a busy bar, health facility, school or coffee shop.























XPREP® Hi-Power Variable-Speed Food Blender with 48 oz. BPA-Free Copolyester Container

MX1200TXP



# XPREP® Hi-Power Variable-Speed Food Blender with 48 oz. BPA-Free Copolyester Container MX1200TXP

## PARTS & ACCESSORIES

- 
**CAC90**  
 64-oz. Stainless Steel Container
- 
**CAC93X**  
 48-oz. Copolyester Container
- 
**CAC93X-03**  
 48-oz. Yellow Copolyester Container
- 
**CAC93X-06**  
 48-oz. Blue Copolyester Container
- 
**CAC93X-10**  
 48-oz. Purple Copolyester Container
- 
**CAC93X-12**  
 48-oz. Green Copolyester Container
- 
**CAC93X-28**  
 48-oz. Orange Copolyester Container
- 
**CAC95**  
 The Raptor™ – Aggressive, All-Purpose, Stackable, 64-oz. BPA-Free Copolyester Container
- 
**CAC95-03**  
 64-oz. Yellow Copolyester Container
- 
**CAC95-06**  
 64-oz. Blue Copolyester Container
- 
**CAC95-10**  
 64-oz. Purple Copolyester Container
- 
**CAC95-12**  
 64-oz. Green Copolyester Container
- 
**CAC95-28**  
 64-oz. Orange Copolyester Container
- 
**CAC116**  
 Blending Assembly Kit and Retainer Ring Kit
- 
**CAC119**  
 Retainer Ring Wrench
- 
**CAC158**  
 Blending Assembly Kit
- 
**CAC159**  
 Retainer Ring Kit
- 
**CAC182**  
 Drive Coupling
- 
**CAC183**  
 Drive Coupling with Square Drive
- 
**CAC161**  
 Drive Coupling Removal Tool
- 
**CAC169**  
 Spatula – Custom designed for use with MX Series Blenders
- 
**SE1500**  
 Sound Enclosure

## DIMENSIONS

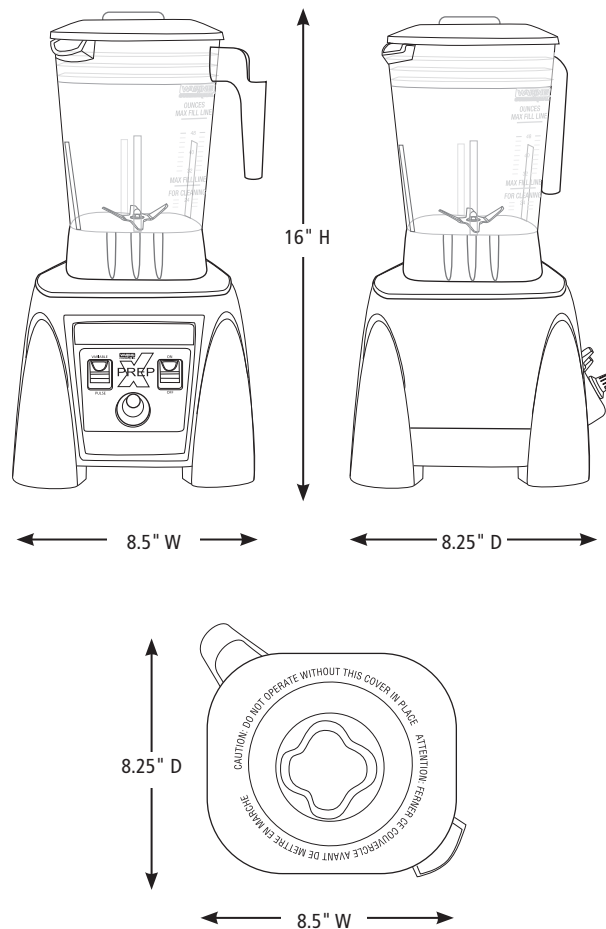

Out-of-Box Weight: 14.4 lbs.

ORDERING INFORMATION	#STD. PKG.	GIFTBOX WEIGHT	CUBIC FEET	BOX DIMENSIONS D X W X H	UPC	CASE PKG.	MC WEIGHT	MC DIMENSIONS D X W X H	MBC
MX1200TXP – XPREP® Hi-Power Variable-Speed Food Blender with 48 oz. BPA-Free Copolyester Container	1	17 lb.	1.059	11.125" x 10.5" x 15.5"	040072031328	1	17.5 lb.	11.75" x 10.75" x 16.375"	10040072031325



# WolfLabs

**Pricing on any accessories shown can be found by keying the part number into the search box on our website.**

The specifications listed in this brochure are subject to change by the manufacturer and therefore cannot be guaranteed to be correct. If there are aspects of the specification that must be guaranteed, please provide these to our sales team so that details can be confirmed.

**[www.wolflabs.co.uk](http://www.wolflabs.co.uk)**

**Tel : 01759 301142**

**Fax : 01759 301143**

**[sales@wolflabs.co.uk](mailto:sales@wolflabs.co.uk)**

Please contact us if this literature doesn't answer all your questions.